

Visible Light Detector

DESCRIPTION

The 412102 is a low cost visible light sensor, with a current output which is directly proportional to the light level. It has a built in optical filter to provide a response which is close to the human eye, or "photopic".

The output current can be converted to a voltage by connecting it in series with a resistor. The dynamic range is determined by the external resistor and power supply (10K and 5V gives a range of 0 to 2000 Lux, but it can be over 6000 Lux with a 1K resistor). The internal dark current cancellation enables high accuracy over the full temperature range, even at low light levels.

FEATURES

- Near human eye photopic response
- High IR rejection – integrated optical filter
- Current output highly linear vs light level
- Temperature stable
- Integrated high gain photo-current amplifier
- Dark-current cancellation
- Light range beyond 6000 Lux

APPLICATIONS

- Dawn/dusk sensing
- Security lighting
- Display backlighting in laptops, mobile phones, LCD TVs
- Night-lights

1.0 Basic application & test circuit

Figure 1

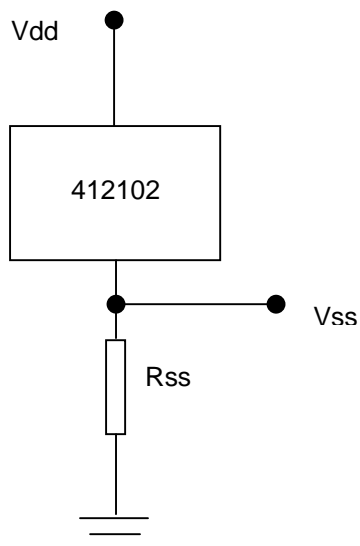

Pin Description

Vdd – Positive terminal

Vss – Negative terminal



412102

Visible Light Detector

2.0 ABSOLUTE MAXIMUM RATINGS

PARAMETER	RATING	UNITS
Supply input voltage	-0.3 to 10	V
Supply current	Internally limited	mA
Operating Temperature, T _O	-40°C to +85°C	°C
Storage Temperature, T _S	-40°C to +100°C	°C

3.0 ELECTRICAL SPECIFICATION

The following parameters apply over the operating temperature range -40°C to +85°C, and with R_{SS}=10 K-Ohms and V_{DD}= 5V, as per figure 1. The 412102 is available as 3 options that is determined by the tolerance of their output current. The table below shows the range of output currents, for specific lighting conditions, for each option.

Parameter	Symbol	Test Conditions	Min	Typ	Max	Units
Infra red response		900 nm		1	5	% of peak
Min. operating voltage	V _{DD} - V _{SS}	I _{SS} =250µA I _{SS} = 50 µA		2.5 1.5		V V
Output Current						
+/- 15%	I _{SS}	2000 Lux 1000 Lux 100 Lux	255 127.5 12.8	300 150 15	345 172.5 17.3	µA µA µA
+/- 25%	I _{SS}	2000 Lux 1000 Lux 100 Lux	225 112.5 11.3	300 150 15	375 187.5 18.8	µA µA µA
+/- 40%	I _{SS}	2000 Lux 1000 Lux 100 Lux	180 90 9	300 150 15	420 210 21	µA µA µA
Dark Current	I _{DRK}	0 Lux, Ta = 25°C 0 Lux, Ta = 85°C		<1 150		nA nA
Gain Linearity			-10		10	%
Peak Spectral Response				520		nm
Sensitive Area				0.054		mm ²
Useable light range		R _{SS} & V _{DD} dependant		6000		Lux

Visible Light Detector

3.1 Selection of R_{ss}

The 412102 can be used over a range of lighting conditions by selecting a suitable value of R_{ss} (see figure 1), or by varying V_{dd}. Also, there is a higher gain version of this device available, the 412101, which is designed to work at lower light levels. This table summarises how to select values of R_{ss}, and shows which device (412101 or 412102) is suitable for each desired application. The graph below also illustrates the usable ranges of both the 412101 and 412102, with 1K Ω , 10K Ω and 25K Ω resistors. Note that for these examples V_{dd} is fixed at 5V.

Light Range	412101	412102
0 to 100 Lux	25K Ω	
0 to 200 Lux	10K Ω	
0 to 900 Lux	1K Ω	25 K Ω
0 to 1700 Lux		10 K Ω
0 to 6000 Lux		1 K Ω

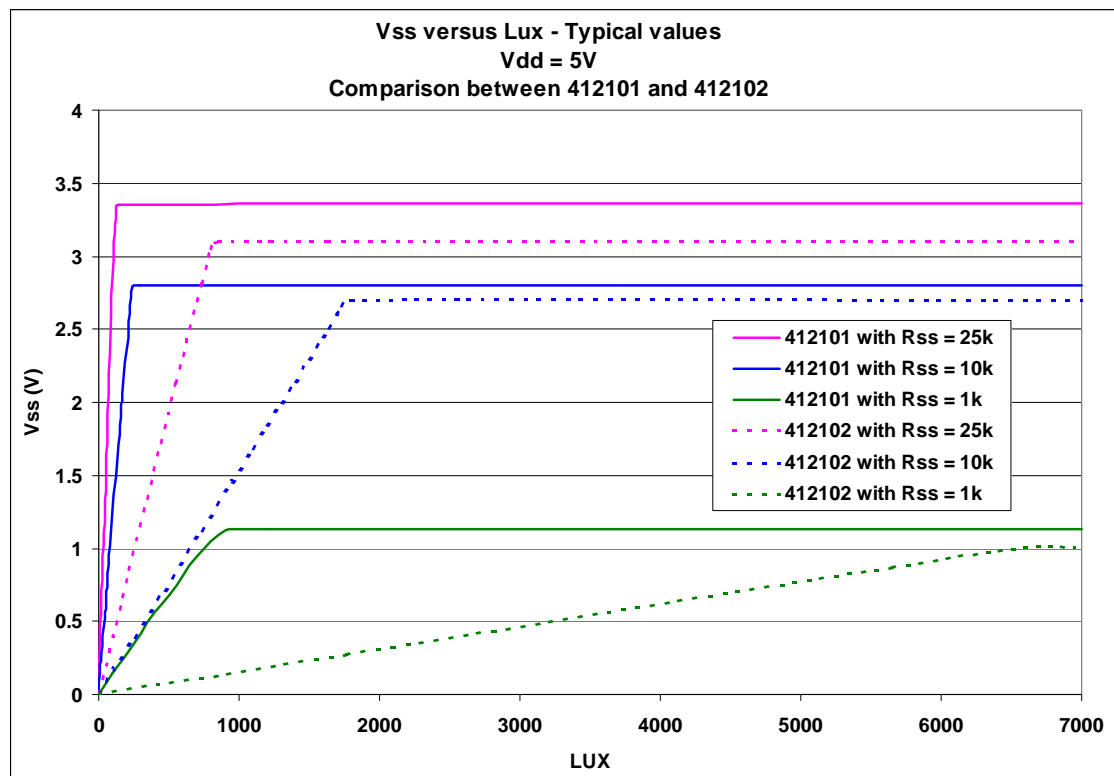

3.2 Characteristic Curves

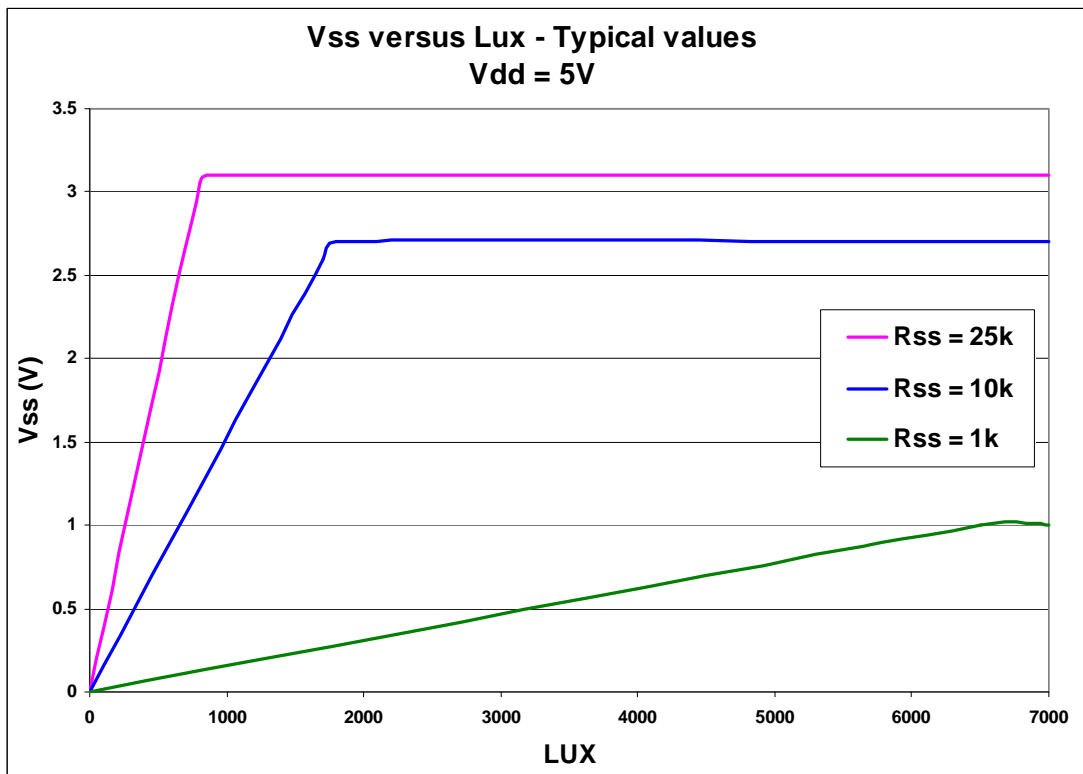
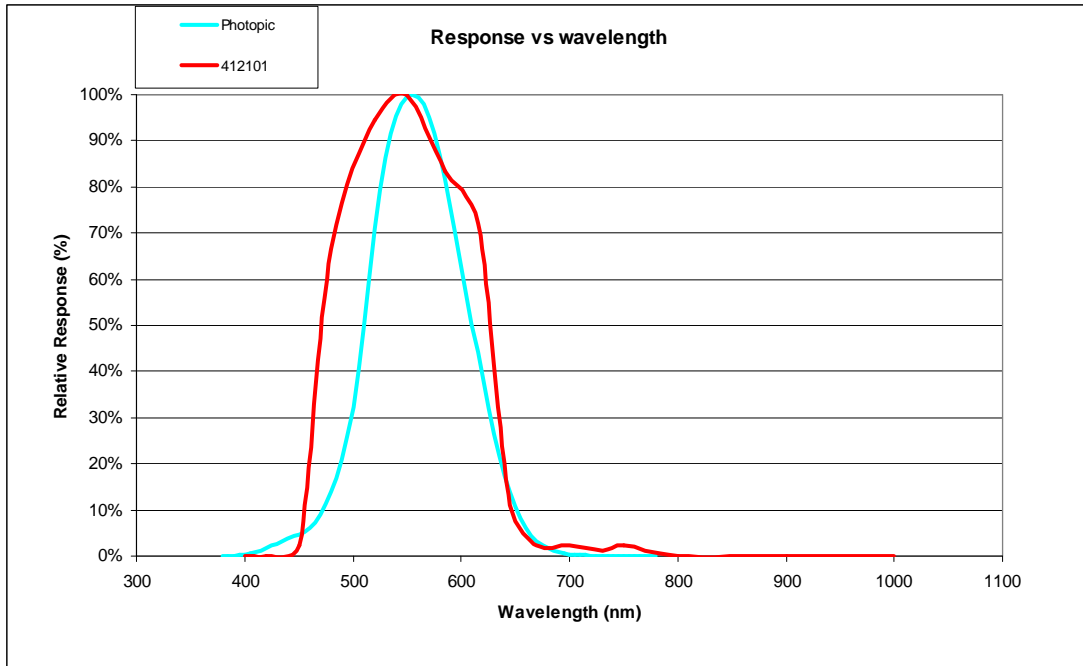

Visible Light Detector

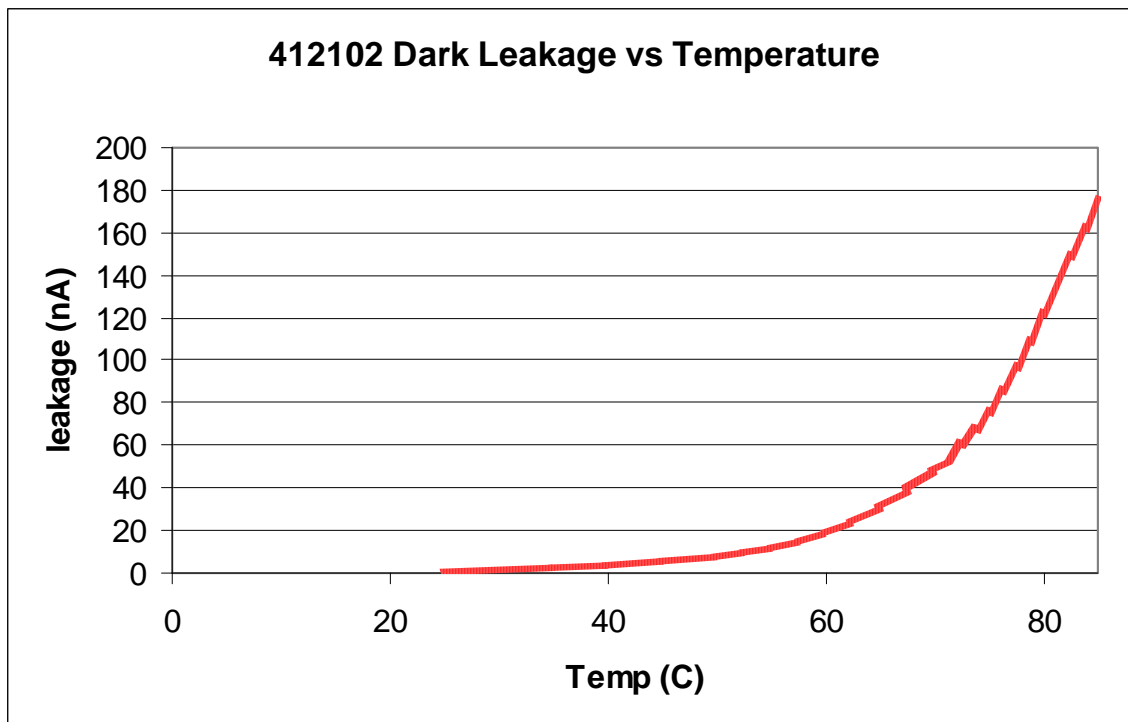
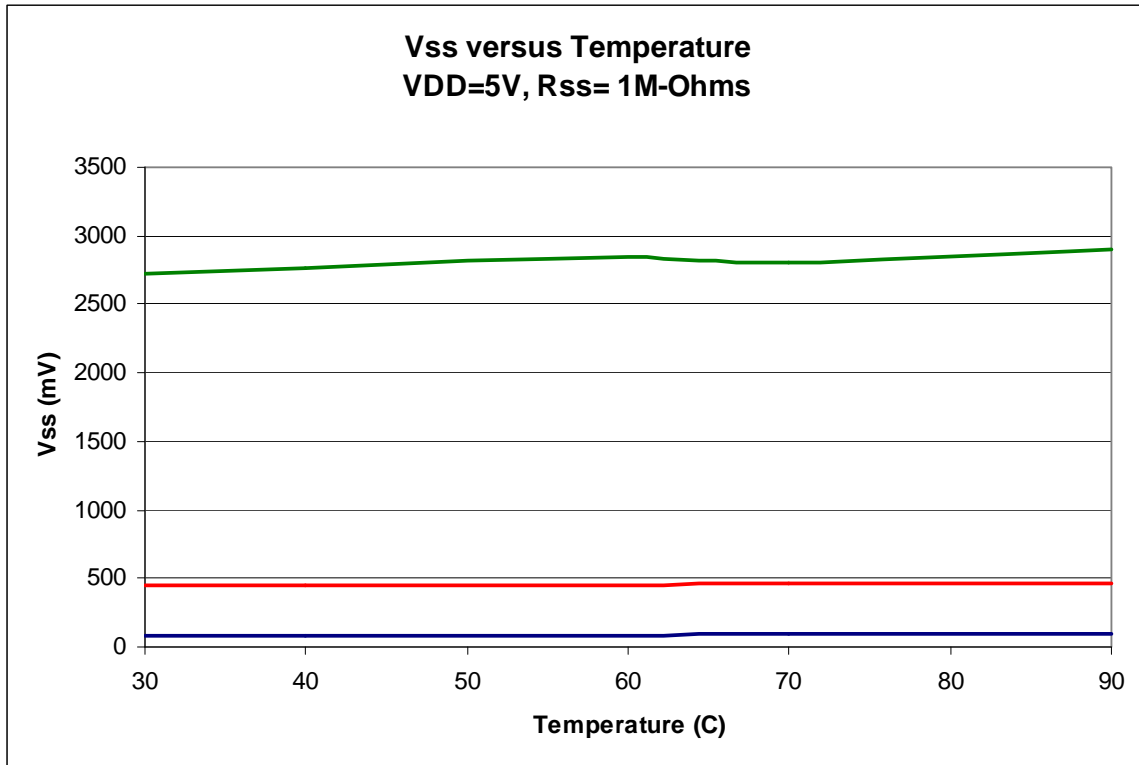

4.0 Application Examples

Automatic Night Light

Fig 2 This circuit shows the 412102 in an Automatic Night Light application.

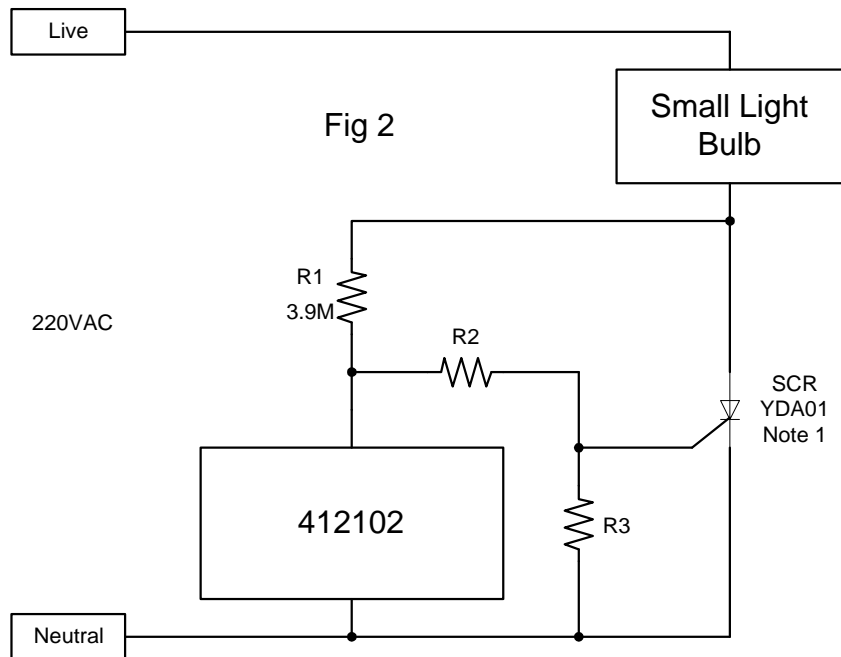

Note 1 This circuit requires a sensitive gate SCR. $i_{gt}(TYP)$ less than $10\ \mu A$

The Lamp current is switched by a sensitive gate SCR. The typical gate current of the SCR should be less than $10\ \mu A$. When the light is above threshold, current flows between the Vdd and Vss pins of the ASIC which diverts current away from the gate of the SCR. The light switching threshold can be adjusted by choosing different values for R2 and R3.

Visible Light Detector

LED Drivers

Fig 3 is a general purpose LED driver.

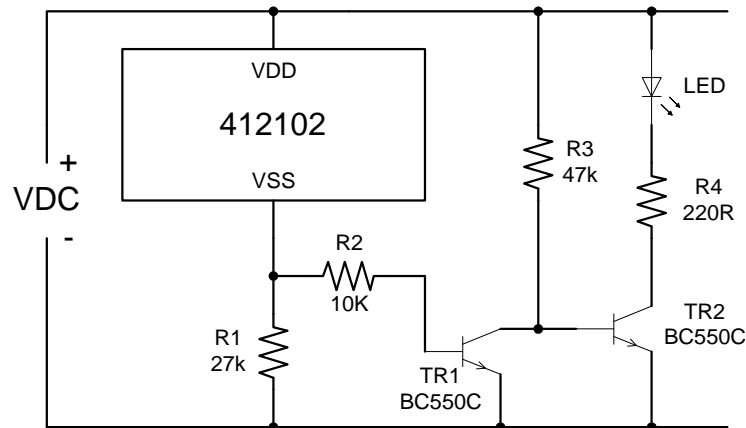

Fig 3

The LED switches ON when the light is less than the switching threshold (Slux). The base current of TR1 will affect the switching threshold. To minimise this effect the base current into TR1 should be less than 10 μ A under all conditions of temperature and supply voltage. When the ambient light >Slux TR1 pulls down R3 and switches off TR2. For battery operated applications low current drain is important and the value of R3 should be as high as possible so that when the LED is off the circuit quiescent current is low. Slux is controlled by R1 and the base emitter voltage of TR1. R2 limits the base current into TR1 to prevent excess current with high illumination. R4 controls the LED current.

Fig 4 In this circuit the LED switches ON when the light is above the switching threshold Slux. The value of R3 in this circuit can be lower than that in Figure 4 because the current in TR1 is switched off in low light conditions.

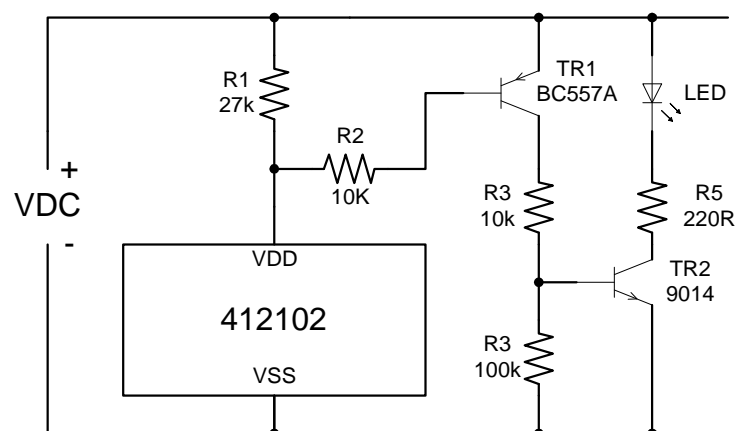

Fig 4

Visible Light Detector

Relay Drivers

Fig 5 The relay coil is energised when the light < Slux.

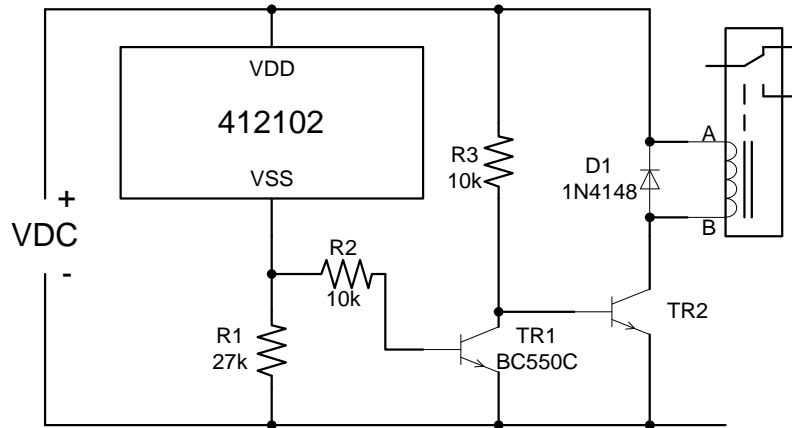

Fig 5

The Slux threshold is set by R1 in the same way as explained in the description for circuit figure 3. For battery operated circuits, the hfe of TR2 should be high to allow a high value for R3. The hfe of TR1 should be high so that a low base current will be able to pull R3 down.

Example:

VDC = 6V, relay coil resistance = 100R. Min hfe of TR2 = 100, min hfe of TR1 = 200

Coil current = 56 mA. Min base current to switch on TR2 = 0.56mA. so R3 = 10K.

Min base current of TR1 = $0.56\text{mA}/200 = 2.8\mu\text{A}$.

With the above value for R3, the quiescent current when the relay is off would be around 0.6mA which might be too high for some battery operated circuits.

Visible Light Detector

Fig 6 The relay coil is energised when light > Slux.

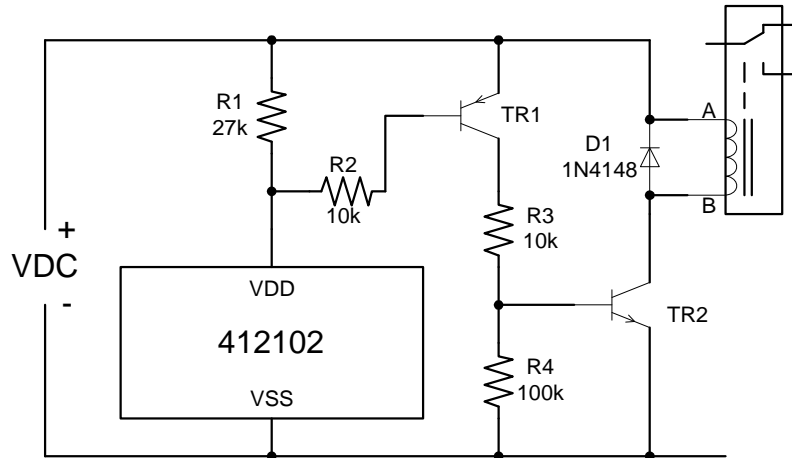

Fig 6

In this case the quiescent current is low in dark conditions because TR1 is switched OFF at the same time as TR2 and the relay coil. The customer can control the current to the application and the quiescent current by choosing a normally open (NO) or normally closed (NC) relay.

Interface Circuit Examples

Fig 7 shows an interface to a microprocessor.

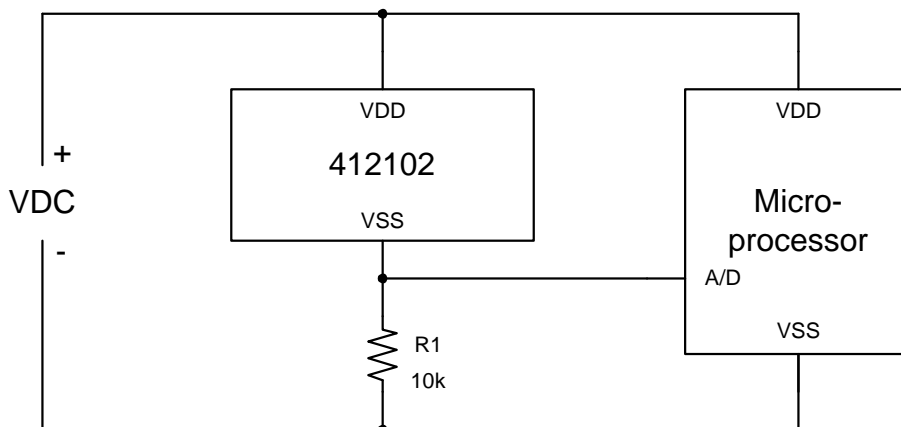

Fig 7

The voltage across R1 varies linearly with the illumination of the sensor. The current between the Vdd and Vss pins is approximately $0.15\mu\text{A}/\text{lux}$, so with a 10K resistor the voltage at the A/D input will be 1.5mV per lux. The headroom required between Vdd and Vss may become a problem at very high lux levels.

Visible Light Detector

Fig 8 This circuit uses a transistor to provide a light level switching interface between the 412102 and CMOS logic.

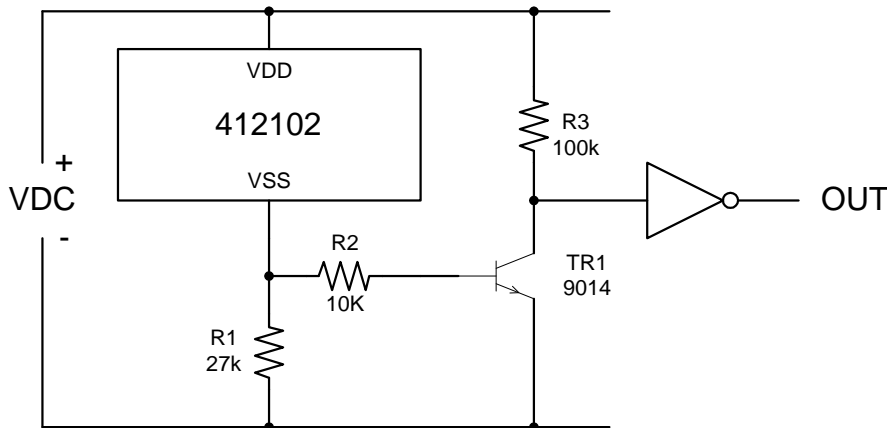

Fig 8

The switching threshold is set by R1 and the base of TR1 as explained for previous circuit examples. The OUT signal will be high when the illumination is above the threshold and low when it is below the threshold. Using a buffer instead of an inverter will change the polarity of the OUT signal

Fig 9 This circuit uses a comparator (or op-amp) to provide a level switching interface for the 412102. OUT will be high when the voltage at Vss < 0.1*Vdd.

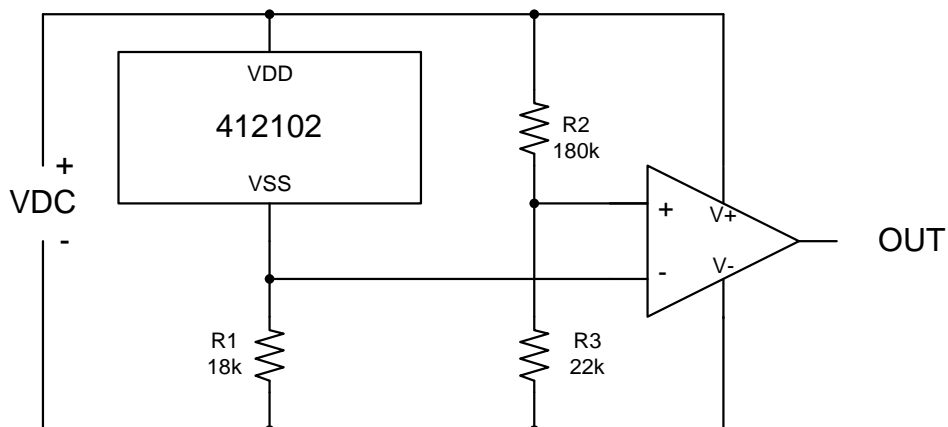

Fig 9

Visible Light Detector

Fig 10 Same as Fig 9 except that OUT will be high when the voltage $V_{ss} > 0.1 \cdot V_{DD}$

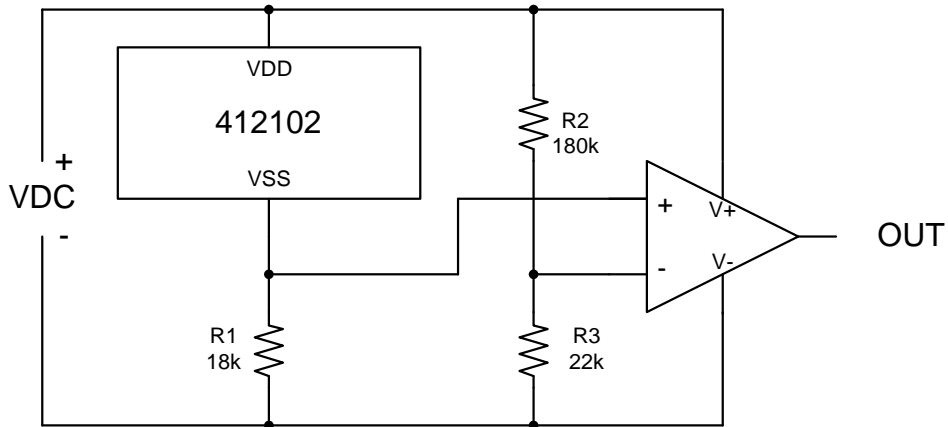

Fig 10

Fig 11 The op-amp circuit amplifies the output voltage at V_{ss} . $V_{OUT} = (1 + R3/R2) I_{photo} \cdot R1$

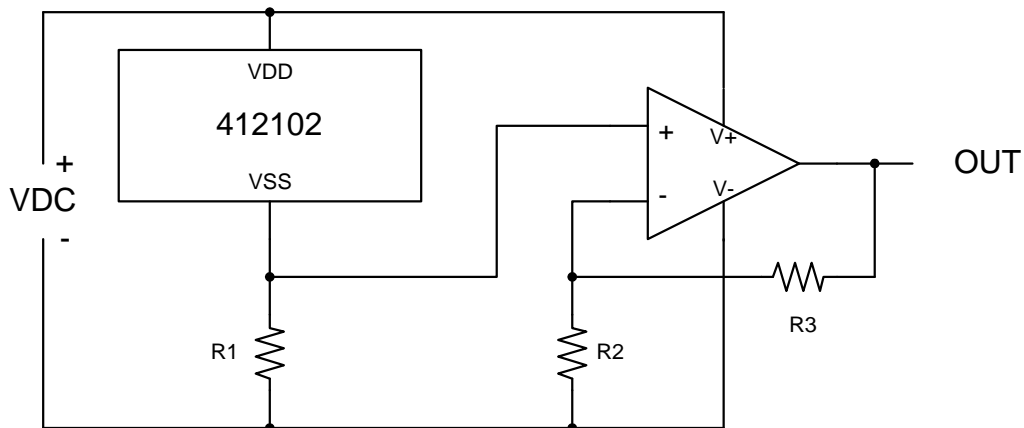

Fig 11

	<p style="text-align: right;">412102</p> <p style="text-align: center;">Visible Light Detector</p>
---	--

5.0 Ordering Information

To order the 412102, please use the order codes defined in the following table:

	Options	Ordering Code
Die Thickness	300 μ m	G
	525 μ m	NG
Output Current Tolerance	+/- 15%	15
	+/- 25%	25
	+/- 40%	40
Supply Format	Bare die, unsawn wafer	D1
	Bare die, sawn wafer	D2
	LED Style package	L
	Surface mount package	S

Examples:

To order sawn wafers, 300 μ m thick, with a tolerance of +/- 40% then use the ordering code:
412102-G-40-D2.

To order 413101 in a surface mount package with 15% tolerance, use ordering code:
412102-15-S

Note: Surface mount style packages require that the wafer be ground down to 300 μ m. For LED style packages, grinding is not required. Therefore in both cases thickness does not need to be specified.