

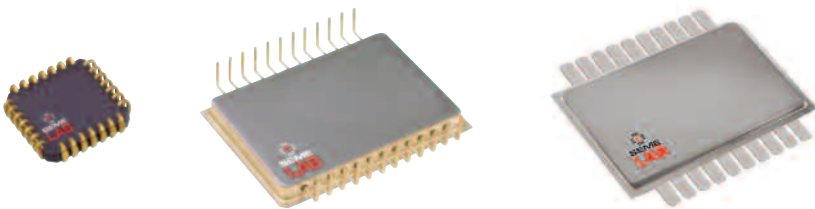

Multi Chip Arrays

High density solutions for power and small signal circuits

AEROSPACE



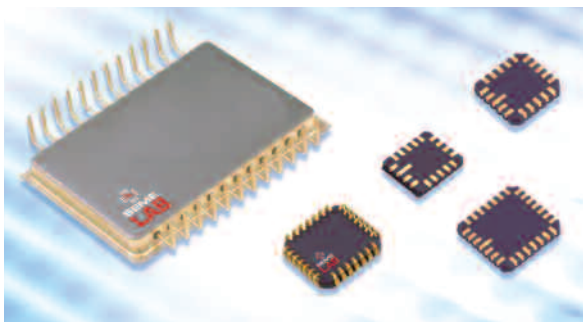
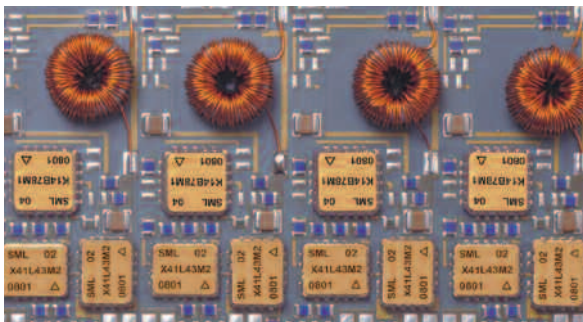

Multi Chip Arrays

Integrated Discrete Components

Multi Chip Arrays (MCAs) integrate several semiconductor die or other components into one package to provide a light and improved-reliability alternative to discrete circuits.

Space Saving

- High density
- Light
- High integration
- Easy interconnection

Cost Effective

- No NRE
- Low cost
- Fast turnaround

Flexible

- Customers' circuit implemented
- Any device technology - active, passive or mixed
- Standard circuits available
- Products for small signal and power
- Proven package technology

Enhanced Performance

- 29 x MTBF of discrete plastic equivalent
- Improved electrical characteristics
- Better thermal matching

Screened

- In accordance with ESA, JANTX and CECC, or as required by customers
- Semelab holds approvals from ISO, DSCC, ESA, CECC, BSI, AQAP, NATO, MUAHAG, GAMT1 and STANAG



Ultra-High Reliability In Discrete Circuits

MCA Applications

- Space equipment - Includes Immarsat, Smart1, ISS, METOP and SIREL
- Civil aircraft (flight-critical systems)
- Undersea systems
- Transportation systems
- Military equipment
- Other harsh environments

Typical MCA Circuits

- Current mirror applications
- Analog interfacing

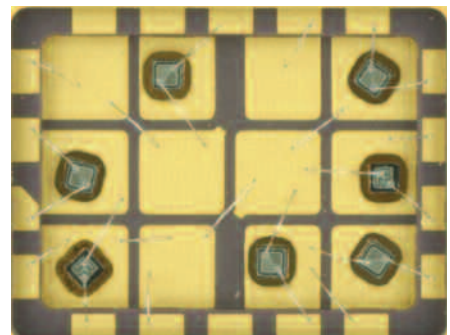

Power MCA

- 24 Pins
- Low Profile: less than 4mm height
- Reduced thermal interface: optimised steady-state thermal performance
- Designed for power products
- Designed for hi-rel: 5000 hour accelerated life and environmental tests completed

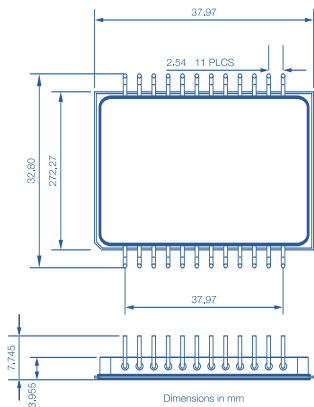
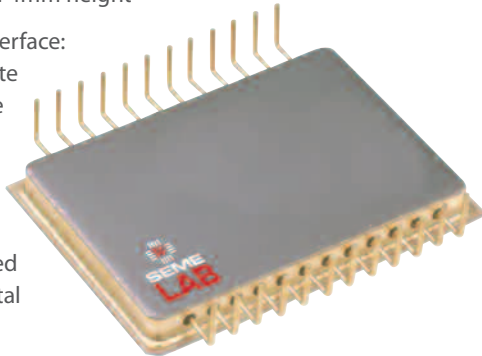

Optional Lead Forming

Surface Mount Power MCA

- Hermetic Si_3N_4 metal package (Silicon Nitride)
- Rugged via hole technology
- Removes the need for standard feed through leads
- Improved thermal performance and reliability

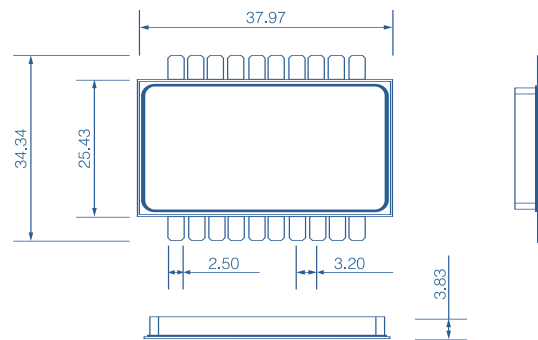
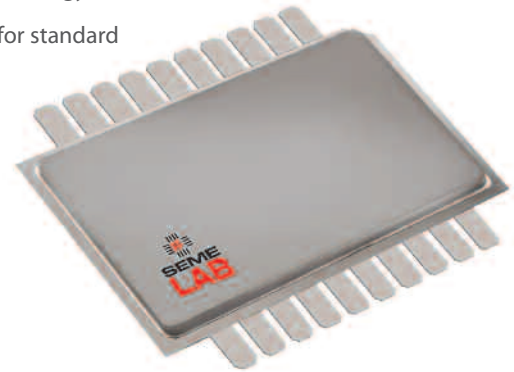

Surface Mount Package

Examples of Standard Designs

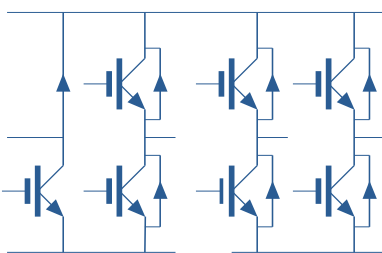

P1

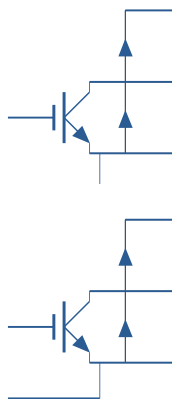

P2

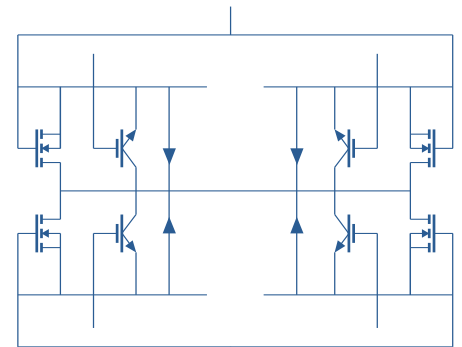

P3

Small Signal MCA

- 18, 20 and 28 pad/lead packages
- Proven packages
- Ultra reliable
- Cost-effective

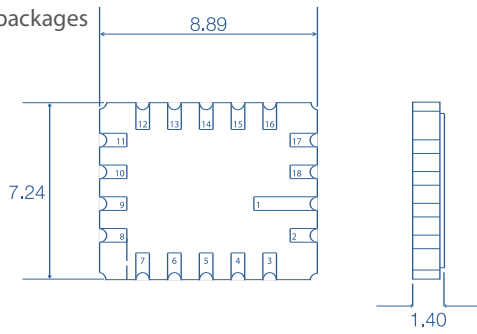
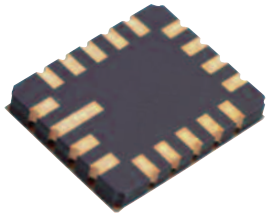

Dimensions in millimetres

MCA 1

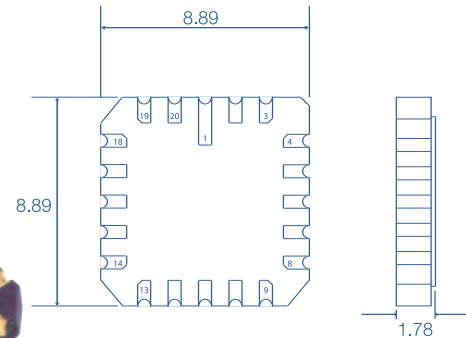
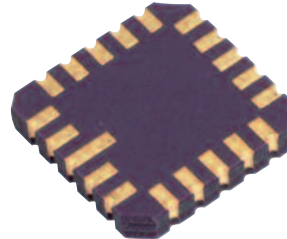

Dimensions in millimetres

MCA 2

Examples of Standard Designs

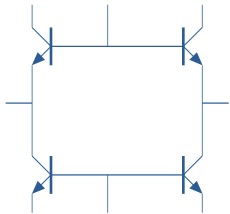

S1 (7 x NPN)

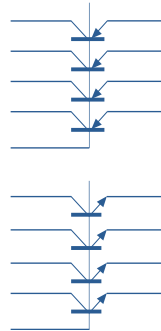

S2 (4 x NPN + 4 x PNP)

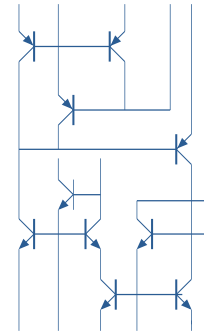

S3 (6 x NPN + 4 x PNP)

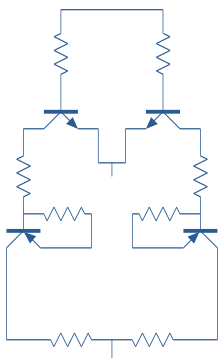

S7 (2 x NPN + 2 x PNP)

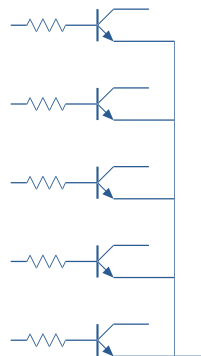

S8 (5 x NPN)

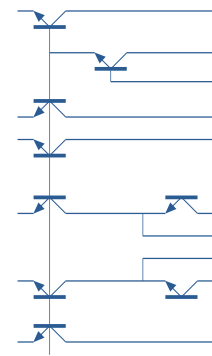

S9 (5 x NPN)

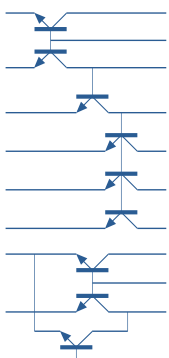

S13 (9 x NPN)

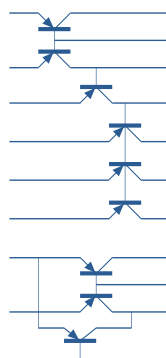

S14 (9 x PNP)

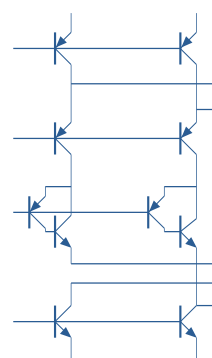

S15 (4 x NPN + 6 x PNP)

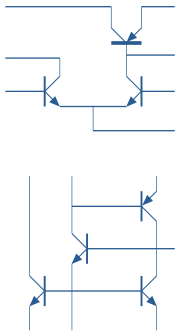
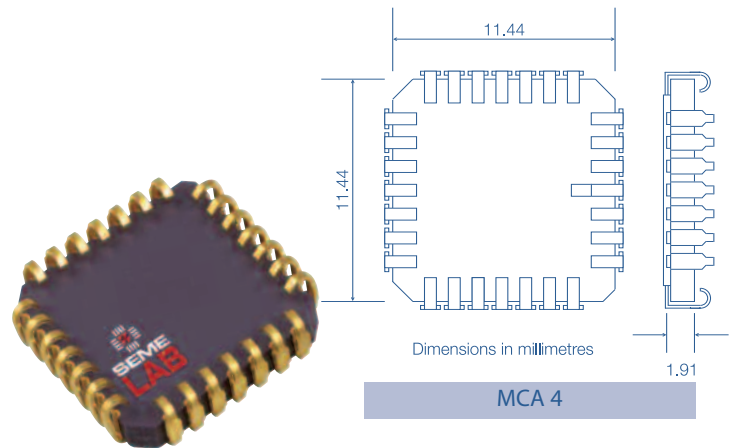
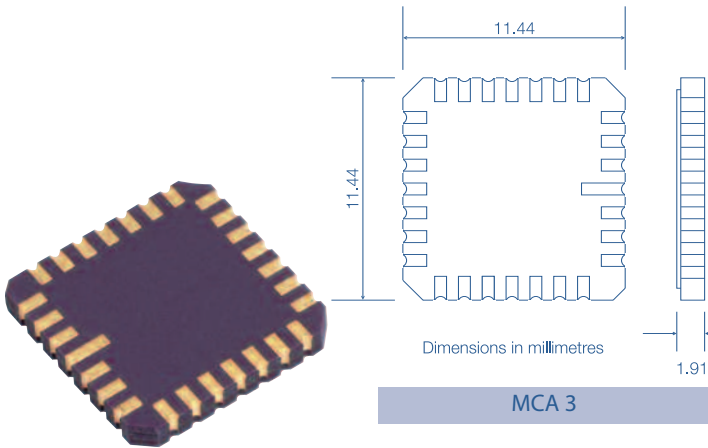

S4 (5 x NPN + 2 x PNP)

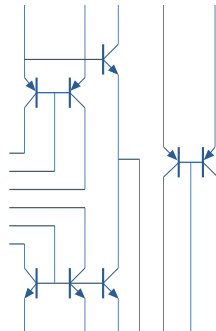

S5 (4 x NPN + 4 x PNP)

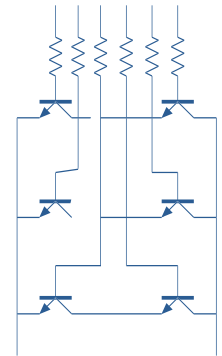

S6 (6 x NPN)

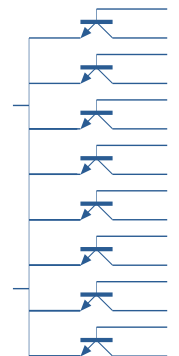

S10 (8 x NPN)

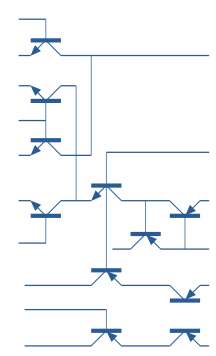

S11 (5 x NPN + 6 x PNP)

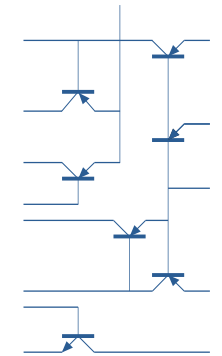

S12 (1 x NPN + 6 x PNP)

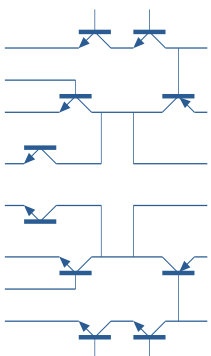

S16 (8 x NPN + 2 x PNP)

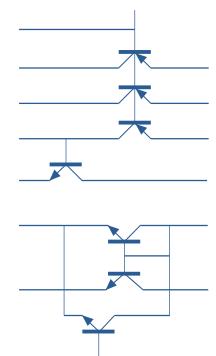

S17 (4 x NPN + 3 x PNP)

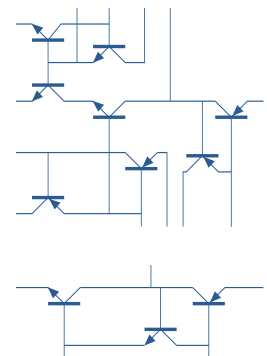

S18 (6 x NPN + 5 x PNP)



MCA Advantages

High Density

Semelab MCAs achieve very high density by integrating many discrete devices and/or technologies in one compact package. Existing designs use up to twelve devices in a single circuit or several separate circuits.

Light Weight

Twelve TO18 packaged devices weigh 3.6g; 12 LCC1 packaged devices weigh 0.48g. The equivalent circuit in MCA weighs less than 0.3g - less than two thirds of the LCC1 equivalent and only 10% of the TO18 weight.

Easy Interconnection

Up to 24 external connections are available on the Power MCA, and up to 28 on small signal MCAs. Because many connections are made within the MCA, PCB design is simpler and quicker.

No NRE

MCAs use standard package outlines and employ fixed islands to create interconnections. Because of this, no package design work is required to create an MCA circuit, and Semelab makes no charge for implementing your design. In cases where customers require specialist testing a small charge may be required for test programming.

Low Cost

In designs completed to date Semelab MCA solutions have reduced component costs by an average of 30% compared to the discrete design.

Fast Turnaround

Samples are usually supplied 2-3 weeks from agreement of design, volume high reliability product 10-12 weeks from receipt of order. (Lead-times subject to availability of piece-parts).

Customer's Circuits And Standard Designs

Semelab can take customers' current designs and advise the best implementation in MCA in most cases. Many standard designs are also available - a selection is shown on the adjacent pages.

Improved Reliability

Using MIL-HDBK-217F Notice 2, calculations for a circuit of twelve 2N2222A transistors operating in an inhabited airborne fighter environment, with a case temperature of 60°C, show the failure rate λ_p as follows:

Plastic discrete transistor system:

$\lambda_p = 6.49$ failures/ 10^6 operating hours

Hermetic discrete system:

$\lambda_p = 0.81$ failures/ 10^6 operating hours

MCA system:

$\lambda_p = 0.22$ failures/ 10^6 operating hours

MTBF is enhanced by a factor of approximately 3.6 by using an MCA instead of hermetic discretes, and by a factor of 29 compared to using plastic discrete components.

Full details of the calculation are available from Semelab.

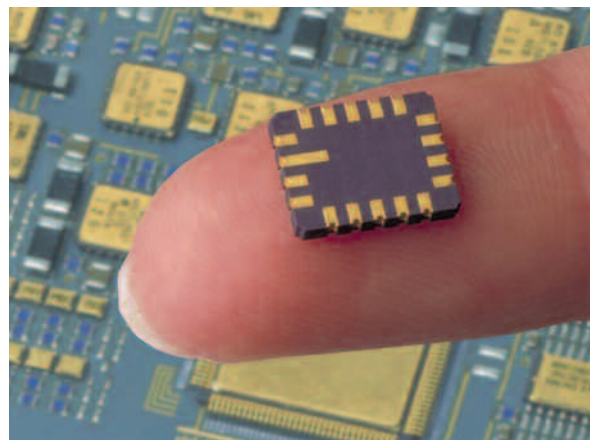



Experience and Innovation in Semiconductor Solutions

Specialists In

- Ceramic surface mount products
- Hermetic metal packaged devices
- Hermetic power modules
- Standard and custom products
- Screening and qualifications
- Continued supply of earlier device types and packages

Semelab holds approvals for many aerospace semiconductor devices, and can manufacture in accordance with CECC, JANTX, ESAlevel 5000 and other major process flows.

MCAs are available with extensive screening options to satisfy almost any hi-rel application.

Please let us know your requirements - we can almost certainly meet them.

Your Semelab Distributor:

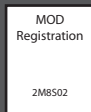
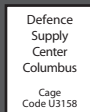

Semelab Plc
Coventry Road,
Lutterworth,
Leicestershire. LE17 4JB
UK

Tel: +44 (0) 1455 556565
Fax: +44 (0) 1455 552612
Email: sales@semelab.co.uk

Web: www.semelab.co.uk
www.semelab.com